

Stadium lamp installation instructions

Rev: A1

Applications:

For stadiums and large squares lighting, can also be used for shipyards, airports, docks and other high pole installation application; can be used for long-distance small-angle projection and large architectural outline lighting.

Cautions:

1. The product should be installed, inspected and maintained by a qualified electrician in accordance with local national electrical safety regulations;
2. Please turn off the power before checking, installing or removing;
3. Ensure that the voltage used is the voltage within the product identification range;
4. Use wires that comply with UL (or other local standards) for wiring. The voltage AC100-277V should be wired with not less than 16 AWG, and the voltage AC277-480V should be wire with not less than 18 AWG;
5. Do not install in a hazardous environment. The ambient temperature must not exceed the rated operating temperature of the product;
6. Do not install the product when it rains. Avoid the danger of lightning strikes and avoid accidents;
7. Please use with listed waterproof strain relief bushing when connecting the power supply cord to outlet box.
8. Can not use the electric generator to test the LED lamp.
9. External 0-10V only passive dimmers are supported.

Wiring diagram:

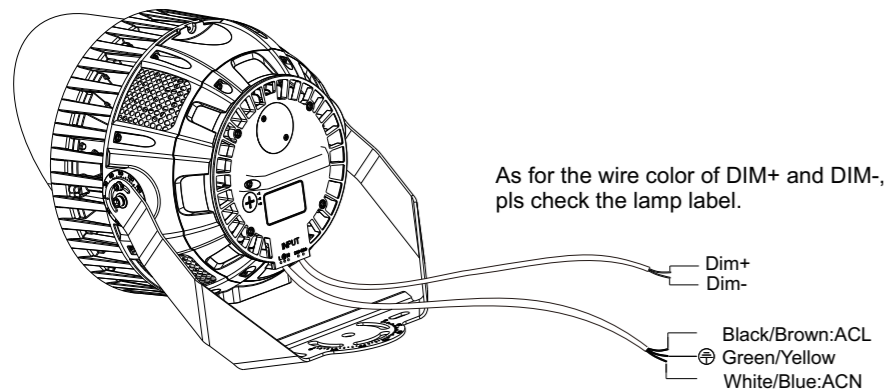

Notice: Please use the dimming+, dimming- (DC10V) marking leads to connect to outside dimmer.
Class 1 Wiring Only.
Please assure a cumulative leakage current of less than 3.5mA on the control circuit.
The AUX control wire with shrinkable tubing shall not be damaged (no connection).

Optional brackets and installation instructions

There are 2 optional brackets for this fixture, the following is sport light fixtures with different brackets

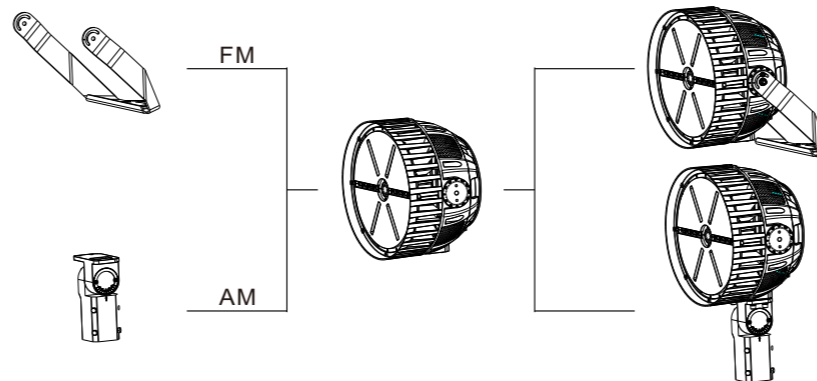

Installation Instructions with different brackets:

1.FLOOD MOUNTING(FM)

- 1: Fix the FM bracket to the heat sink with M10 screws (Figure 1);
- 2: Fix it with M6 screws after adjusting to the required the angle (Figure 2).

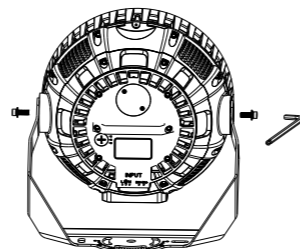

Figure 1

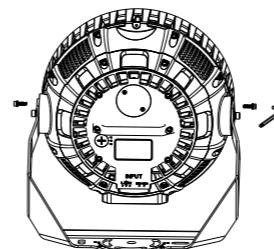

Figure 2

2.ADJUSTABLE FITTER MOUNTING(AM)

- 1: Remove the bracket mounting screws on the fixture and run the wires through the bracket. (Figure 3)
- 2: Install the bracket on the fixture. (Figure 4)

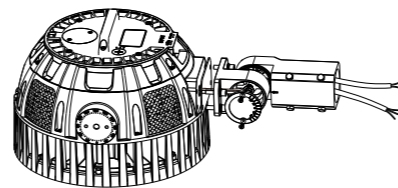

Figure 3

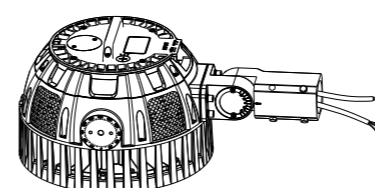

Figure 4

Flood mounting method I (pole mounting) :

1. Mark the hole distance S1 shown in the product to be installed (Figure 5);
2. Drill two holes of distance S1 on the mounting bar (Figure 6).

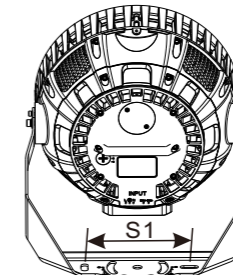

Figure 5

POWER	400/500W
S1	190mm

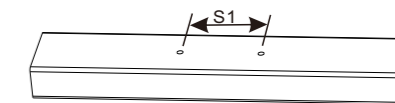

Figure 6

3. Install the luminaire on the crossbar and secure it with nuts, spring washers and flat washers (Figure 7).

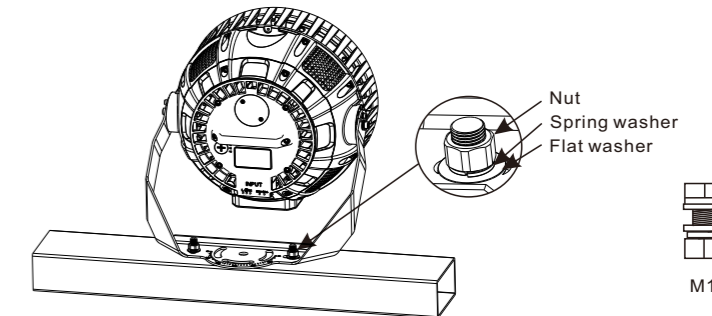

Figure 7



M12

4. Use M6 hex wrench to loosen the adjustment screw used to adjust the angle (Figure 8).

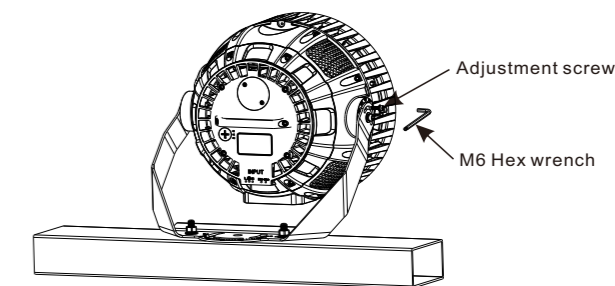

Figure 8

5. According to the need, adjust the projection angle, angle adjustment range; (Figure 9)

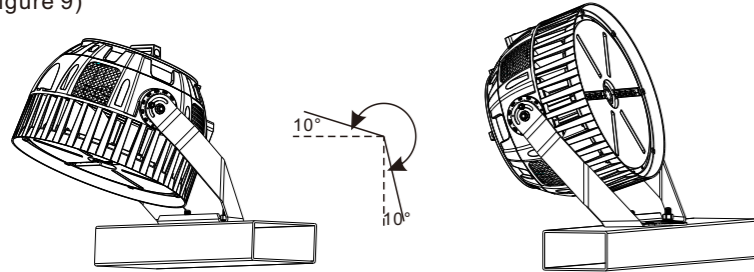

Figure 9

6. Complete the projection angle adjustment and lock the adjustment screw;
7. According to the previous wiring diagram and select one desired method for wiring.

Notice: Please use listed water proof strain relief bushing when connection the supply cord to the outlet box.

Flood mounting method II (disc holder installation):

1. Fix the product on the disc holder and lock the screws, no need too tight. (Figure 10);
2. According to the need to adjust the lighting direction, can be 360 degrees rotation adjustment, tightened with screws when the adjustment is completed (Figure 11);

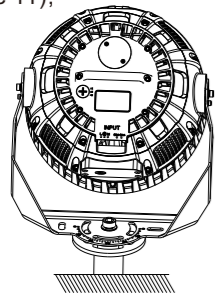

Figure 10

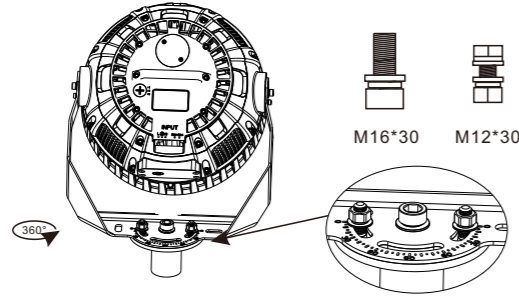

Figure 11

3. Use an open-end wrench and hex wrench to loosen the adjusting screw for adjusting the angle (Figure 12)

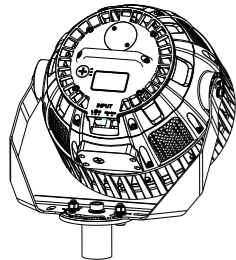

Figure 12

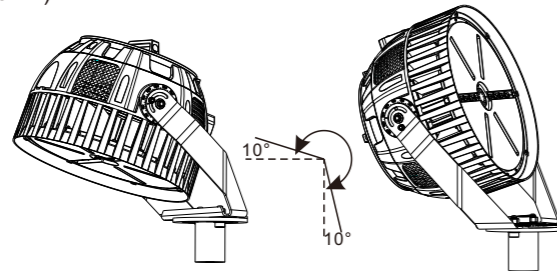

Figure 13

4. According to the need, carry out the projection angle adjustment, angle adjustment range (Figure 13);
5. Complete the projection angle adjustment and lock the adjustment screw;
6. According to the previous wiring diagram and select one method for wiring. Notice: Please use listed water proof strain relief bushing when connection the supply cord to the outlet box.

ADJUSTABLE FITTER MOUNTING (AM)

1. Loosen the 4 locking bolts on the slip fitter, connect the wire correctly and put the wire into pole. Then fasten the locking bolts between slip fitter and the pole. (Figure 14)
2. Loosen the fixing bolts and adjusting bolts, align the fixture to required angle. Tighten adjusting bolt and fixing bolts after the angle is confirmed. (Figure 15)
Notice: Adjustable angle is 0-90° (Figure 14).

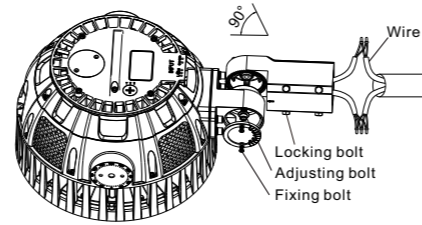

Figure 14

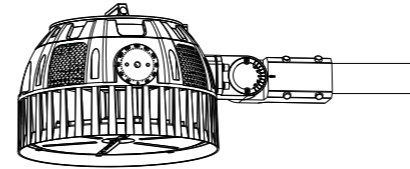

Figure 15

Instructions for light shield

When the light shield function is required, Fix the light barrier to the luminaire with a screwdriver as required. (Figure 16)

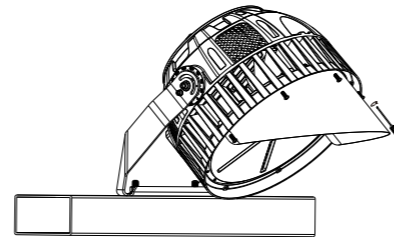

Figure 16

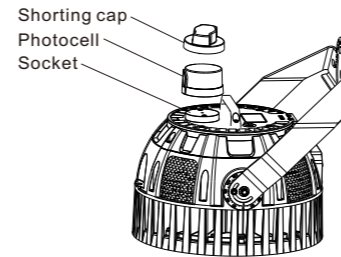

Figure 17

Instructions for Photocell

When the photocell function is required, photocell should be installed on the back of lamp; When it's not required, shorting cap should be installed on the back of lamp. (Figure 17)

The explanation for wattage selection :

The light fixture with watt adjustable function, tear off the plug, switch it to the tap position you need. (300W, 400W, 500W, Factory setting: "500W") (Figure 18)

Note: only switch the tap position to "500W", the light fixture recover to the standard status.

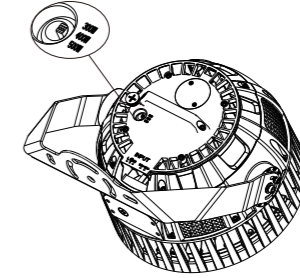

Figure 18

MIN 75 °C SUPPLY CONDUCTORS
THIS PRODUCT MUST BE INSTALLED IN ACCORDANCE WITH THE APPLICABLE INSTALLATION CODE BY A PERSON FAMILIAR WITH THE CONSTRUCTION AND OPERATION OF THE PRODUCT AND THE HAZARDS INVOLVED.
ALL COMPONENTS IN THE LUMINAIRE SHALL NOT BE REPLACED OR SERVICED.
LES FILS D'ALIMENTATION 75 °C
CE PRODUIT DOIT ÊTRE INSTALLÉ SELON LE CODE D'INSTALLATION PERTINENT, PAR UNE PERSONNE QUI CONNAÎT BIEN LE PRODUIT ET SON FONCTIONNEMENT AINSI QUE LES RISQUES INHÉRENTS.