



PROJECT NAME

CATALOG NO.

TYPE

DATE

NOTE

## VOLUMETRIC LED TROFFER

**STL Series**  
Panels and Troffers

### DESCRIPTION

The STL architectural LED Troffer series combines the benefits of long life, controllability, and energy savings with elegant design and superior quality of light. The STL luminaires optimize LED optics and electronics to deliver energy savings and high performance.

### APPLICATION

Indoor general/ambient illumination. Ideal for offices, schools, retail, and other architectural spaces that demand energy demand reduction and high quality light.



### SPECIFICATION FEATURES

#### Construction

Rugged construction: solid die-formed, cold-rolled steel. Interior utilizes highly reflective powder coat finish. All surfaces coated and baked post-fabrication with high gloss powder-paint. Diffuser lens provides even and consistent light while eliminating pixelation. Driver are replaceable. Housing and optics maintain damp location rating with all internal components.

#### Electrical

Luminaire utilizes long life, high efficacy LEDs and a highly efficient, reliable LED driver. 120V-277V input voltage for increased versatility. 0-10V continuous dimming comes standard. Comes equipped with quick disconnect for compliance with US code

#### Mounting

Installs recessed with T-bar grid. Surface mount and flange mount kit available as options.

#### Finish

Highly reflective powder coat finish. Baked white matte paint, applied after fabrication.

#### Optics

Precision formed optical assembly with positively retained high optical grade acrylic lenses deliver a comfortable mix of light to working and surrounding surfaces, creating balanced illumination throughout the environment. Occupants can realize a productive and comfortable atmosphere through enhanced light quality and distribution.

#### Certifications / Regulatory

UL/cUL listed. Damp location rated. All components used have UL approval. UL Class 2. Power supply: SCP, OTP, OVP protection, FCC Part 15 Class B, UL8750 Class 2. DLC Standard listed.

#### Warranty

7-year limited warranty. See complete warranty terms for details.

**Quick Ship Product**

## ORDERING INFORMATION

Sample Number: **STL-24A/8A**

STL	24	A	8	A	(Blank)	(Blank)
<b>Series</b> STL - Volumetric LED Troffer	<b>Form Factor</b> 22 - 2'x2' 24 - 2'x4'	<b>Lumen Package</b> A - Adjustable Wattage *See energy data for details	<b>CRI</b> 8 - 82+ CRI	<b>CCT</b> A - Adjustable	<b>Input Voltage</b> (Blank) - 120V-277V	<b>Dimming</b> (Blank) - 0-10V Continuous Dimming

### Options

#### Controls

**SMC** - Smart Control System

#### Emergency Backup

(Lumen will maintain over the 90-minute duration)

**EM700** - 700lm

**EM1400** - 1400lm

**EM2000** - 2000lm

SUMMARY

Input Voltage	120V-277V
Input Power	See energy data for details
Power Factor	> 0.95
THD (Max.)	20%
Efficacy	> 110 LPW
Delivered Lumens	See energy data for details
Controls/ Dimming	Full Range 0-10V dimming standard
Dimming Range	0-10V Continuous (10-100%)
CRI	> 83
CCT	Adjustable (3500K, 4000K, 5000K)
Operating Temp.	-20 ~ +55 C
Rated Life	70,000 hours

ENERGY PERFORMANCE DATA

Form Factor	Part No.	Rated Wattage (W)	Tested Wattage (W)	Delivered Lumens (lm)	Efficacy (lm/W)
2'x2'	STL-22A/8A	40/30/20	40/30/20	5000/3750/2500 +/- 5%	125
2'x4'	STL-24A/8A	46/36/28	46/36/28	5750/4500/3500 +/- 5%	125

PHYSICAL PARAMETERS

DIMENSION

STL-22

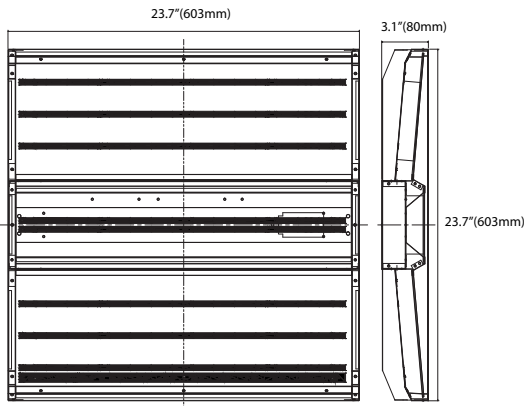

STL-24

