

## PRODUCT DESCRIPTION:

Energy saving lamps and lanterns with high lumen, perfect color temperature and high CRI characteristics.

### Application:

- Gas station lighting
- Petroleum canopies lighting
- CNG fueling stations lighting
- Low-medium bay general lighting
- Soffits lighting

## FEATURES:

- SMD LED chips
- Aluminum die-casting heat sinks for good heat dissipation
- No RF interference, no IR/UV radiation or mercury pollution

## DIMENSIONS:

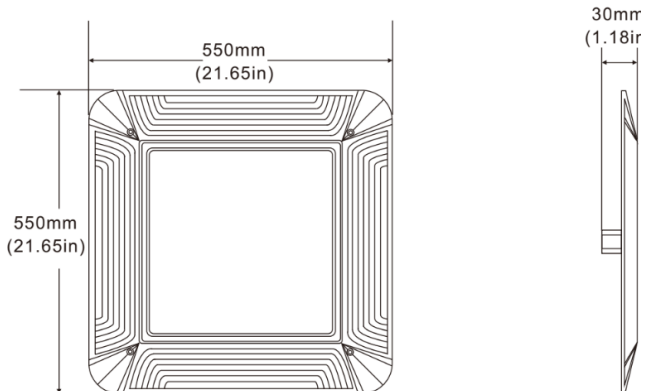

## LED 150W Gas Station Light

RL-CP-150W-H3-M2-N-DW



## SPECIFICATIONS:

SPECIFICATION	Details
Model	RL-CP-150W-H3-M2-N-DW
Input Wattage (W)	150W
Lumens Delivered (LM)	19,319.1LM
Efficacy (LM/W)	135.01LM/W
CRI	70
Lifespan	50,000 hours
Color Temperature	5,000K
Wattage Equivalent	500W
Dimmable	Available
Input Voltage	AC100-277V
Power Factor	0.9
Housing	Aluminum Alloy + PC shell
IP Rating	IP65
Lens	Frosted
THD	15%
Beam Angle	120 degree
Size and Weight (LBS)	21.65" X 21.65" X 1.18" 30.86lbs
Certification	DLC, ETL
Operating Temperature	-40 to 45°C
Environment	Outdoor
Warranty	5 years

