

Date: \_\_\_\_\_ Location: \_\_\_\_\_  
 Product: \_\_\_\_\_ Project: \_\_\_\_\_  
 Quantity: \_\_\_\_\_ Catalog #: \_\_\_\_\_

## LED LOC-LHB V2 Linear High Bay Light Series



110W or 160W

**Special Order:**

- Other CCTs

**CONSTRUCTION:**

PMMA lens material. Steel and aluminum body.

**OPTICAL SYSTEM:**

Samsung 2835 LED chips. Frosted lens. 120° beam angle options.

**WARRANTY:**

5-year limited warranty. Actual performance may differ as a result of end-user environment and application.

**ELECTRICAL:**

Available as 120-277V input. -20°C to 40°C

**INSTALLATION & MOUNTING:**

Hanging hook or pendant mount.

**CONTROLS & DIMMING:**

0-10V dimming comes standard. Suitable for use with LED dimmers. Motion sensor and remote-control options available.

**FEATURES**

- IP54 rated
- Easy installation and maintenance
- 100,000 hours lifetime

**SUITABLE APPLICATIONS**

- Warehouses
- Stadiums
- Factories
- Supermarkets
- Logistic Centers
- Exhibition Halls



MODEL NUMBER – 4,000K 5,000K	WATTAGE	LUMENS	EFFICACY	CRI	POWER FACTOR	THD	REPLACES
LOC-LHB110W-40K-V2-[Blank,EM]-[Blank,MS]	110W	14,596LM	131.5LM/W	80	0.9	20%	250W HID
LOC-LHB110W-50K-V2-[Blank,EM]-[Blank,MS]	110W	14,718LM	132.6LM/W	80	0.9	20%	250W HID
LOC-LHB160W-40K-V2-[Blank,EM]-[Blank,MS]	160W	21,123LM	131.2LM/W	80	0.9	20%	400W HID
LOC-LHB160W-50K-V2-[Blank,EM]-[Blank,MS]	160W	21,203LM	131.7LM/W	80	0.9	20%	400W HID

Series	Wattage	CCT Options	Dimming Options	Version
LOC-LHB	110W 160W	4,000K 5,000K	0-10V Dimming Integrated Motion Sensor	V2 = Version 2
<b>Optional</b>				
MS - Motion Sensor EM – Emergency Battery				

## MEASUREMENTS

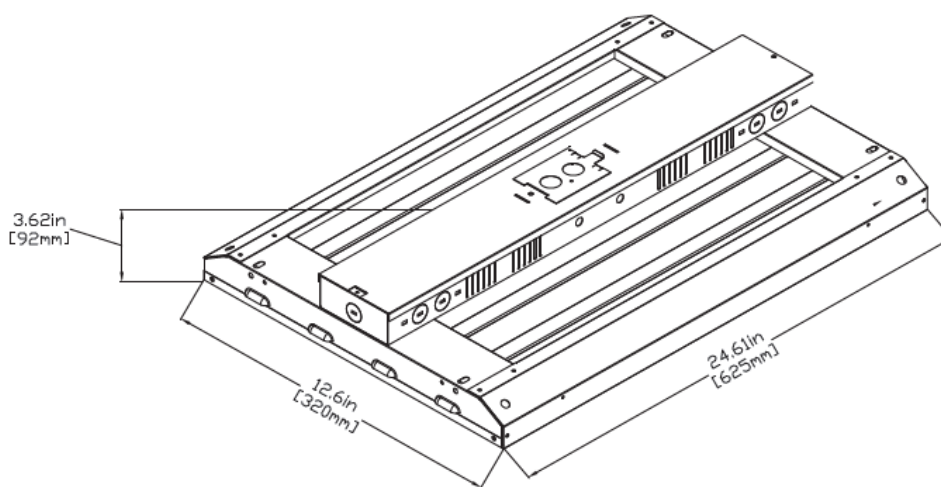

110W or 160W

MODEL	QUANTITY	WEIGHT	UPC CODE
LOC-LHB110W-40K-V2-[Blank,EM]-[Blank,MS]	1	10.80 lbs	0081558602
LOC-LHB110W-50K-V2-[Blank,EM]-[Blank,MS]	1	10.80 lbs	00815586025046
LOC-LHB160W-40K-V2-[Blank,EM]-[Blank,MS]	1	10.80 lbs	0081558602
LOC-LHB160W-50K-V2-[Blank,EM]-[Blank,MS]	1	10.80 lbs	00815586021406

## 110W

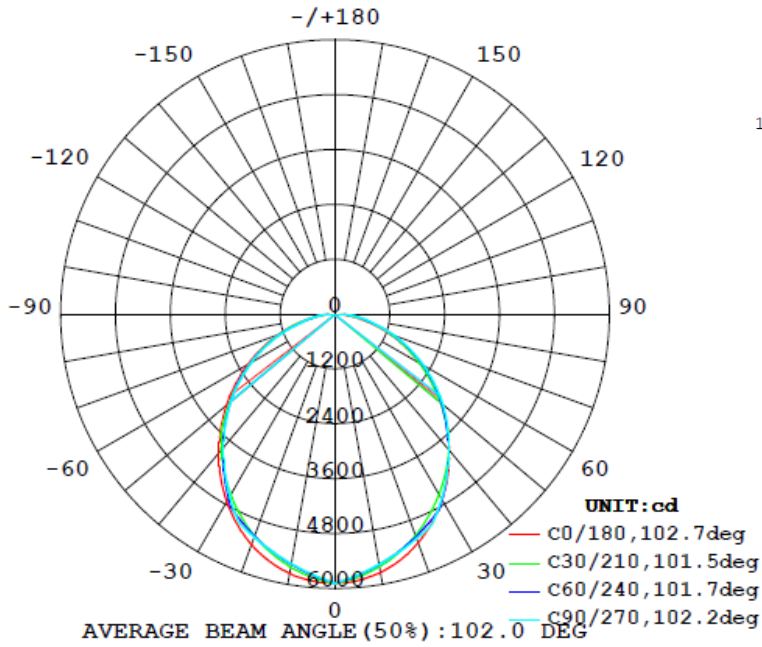

Flux out: 10023 lm

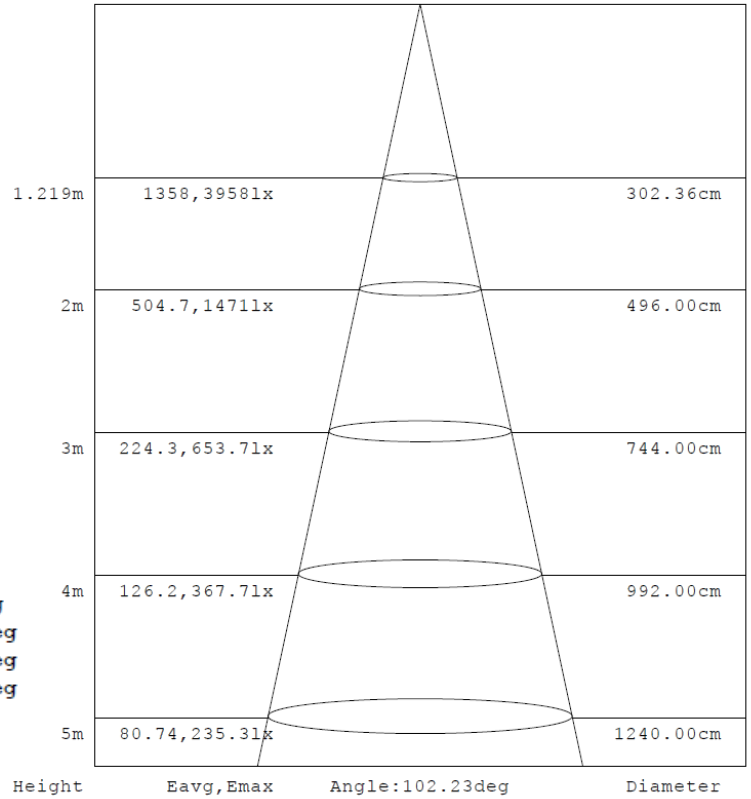

Note: The Curves indicate the illuminated area and the average illumination when the luminaire is at different distance.

## 160W

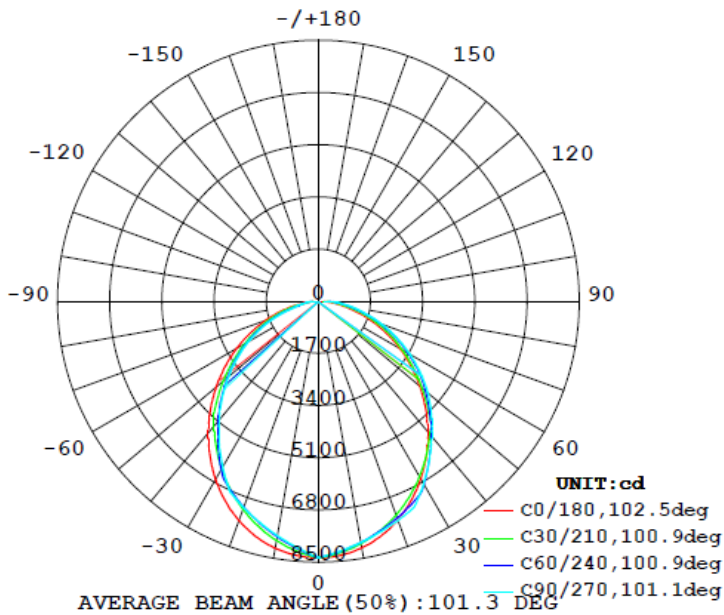

Flux out: 13996 lm

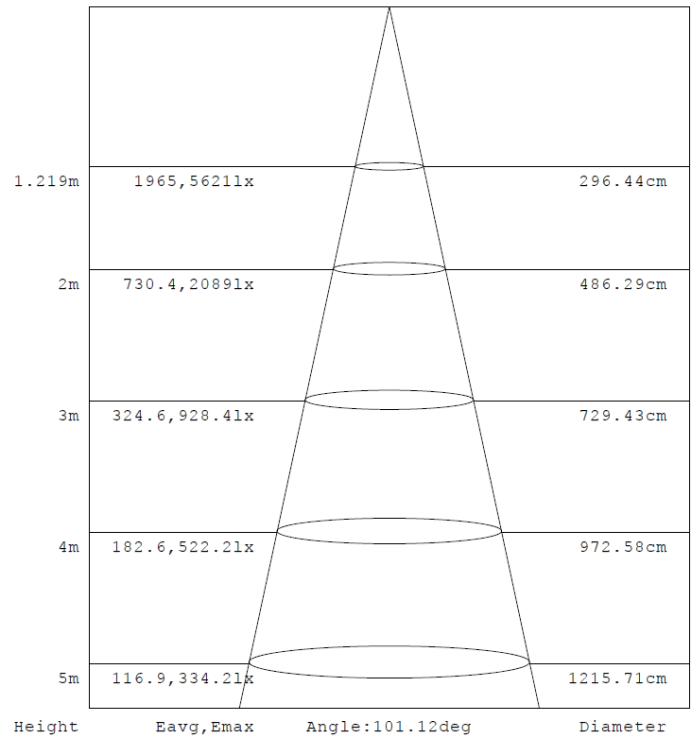

Note: The Curves indicate the illuminated area and the average illumination when the luminaire is at different distance.

# MOUNTING OPTIONS

Pendant Mount



Chain & Hook



# OPTIONAL ACCESSORIES



Non-Dim Motion Sensor  
LOD-BRI819P-B-O



Motion Sensor  
LOD-BRI819P-B-D



Remote Control  
LOC-RC100



Emergency Driver  
LOC-EMDR-25WHV