

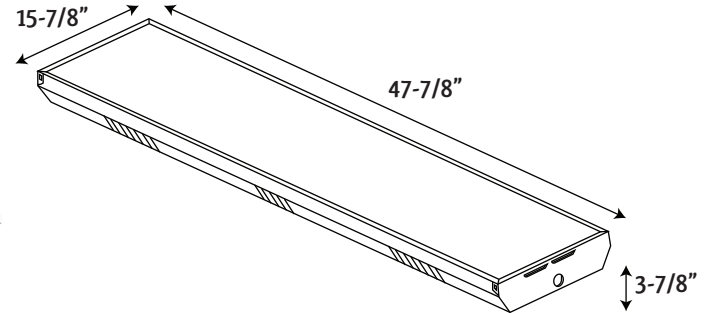

DIMENSIONS:



LLHB-180W-50K-D LLHB-180W-40K-D

LED Linear High Bay

Ideal for one-on-one replacement of conventional lighting systems such as HID and fluorescent. Applications include manufacturing, warehousing and other large indoor spaces with mounting heights from 10'-40'. Luminaire shall be suspended a minimum 24" from ceiling. Surface mounting is not permitted.

ELECTRICAL SPECIFICATIONS:

- Voltage: 100~277 AC
- Wattage: 180W
- Other wattages available in this model: 120W and 240W
- Lumens: 22,500LM
- Color temperatures: 5000K and 4000K
- CRI: >80
- Power factor: >0.95
- 0~10 dimming
- Electrical (option): Sensor & Emergency fitting
- Housing: Steel, powder coated white
- Lens: Clear PMMA
- With V-hook
- Driver: Towin

CERTIFICATIONS:

Tested in accordance with IESNA LM-79 and LM-80 standard.



MODEL	WATTS	VOLTS	LUMENS	COLOR TEMP
LLHB-180W-50K-D	180W	100~277V AC	22,500LM	5000K
LLHB-180W-40K-D	180W	100~277V AC	22,500LM	4000K

CONSTRUCTION:

- Specification grade housing and end plates are die formed cold rolled steel. Westgate Linear LED High bay offers a classic yet an advanced and modern look with most efficient integrated LED strips.

FINISH:

- All metal parts painted, coated with high reflectance polyester powder and treated with phosphate rust inhibitor.

ELECTRONICS:

- Long-life LED system coupled with electrical driver to deliver optimal performance.

WARRANTY: 5 years

- Consult factory for special orders: Emergency Battery Backup, Motion Sensor, Step-dimming Sensor, and any other color temperature.