

## LED DOUBLE RING FLUSH MOUNT CEILING LIGHT (AC120-277V)

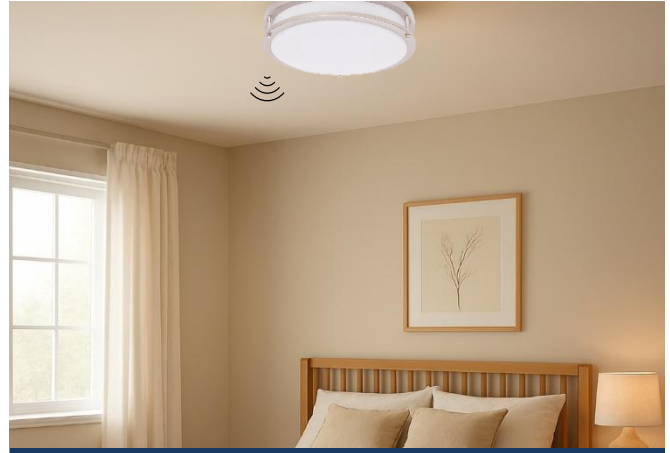



**Application:** Ideal for drawing rooms, bedrooms, corridors, and administrative offices.

### CERTIFICATIONS



### BI-LEVEL SENSOR & EMERGENCY BACKUP

<b>ANT-1M-5T</b> (Bi-level Daylight Harvesting Microwave Sensor)	
<b>Emergency Backup</b>	

### FEATURES

The LED Double Ring Flush Mount Ceiling Light is versatile, efficient, and built to last. It features tunable white light (2700K–5000K), 0–10V dimming, high luminous efficiency, and excellent color rendering. Available in Bi-Level Motion Sensor + Emergency Driver version, it combines a durable stainless steel body with a polycarbonate diffuser and comes with a 5-year limited warranty.

### SPECIFICATIONS

Model No	HY-DR12-16WCCT(MS+EM)	HY-DR14-22WCCT(MS+EM)	HY-DR16-26WCCT(MS+EM)
Wattage	16W	22W	26W
Size	12"	14"	16"
Lumens	1600 LM	2200 LM	2600 LM
Rated Input Voltage(V)	120-277 VAC		
CCT	2700K/3000K/3500K/4000K/5000K		
Beam Angle	120°		
Dimming	0-10V dimmable		
Color Rendering Index	>80		
Power Factor	>0.90 <span style="float: right;">✱</span>		
Working Temperature	-13°F ~ +113°F / -25°C ~ 45°C		
Environment Location	IP 20 – Indoor Only		
Lifespan	Lumen Maintenance over 70% @ 50,000+ Hours		
Body Finish	Brushed Nickel		
Charging Time	≥24 Hours		
Emergency Time	< 1.5 Hours		
Package Dimensions	27.2"X12.7"X12.9"	29.6"X14.6"X14.8"	33.1"X16.7"X16.9"
Package Weight	19 LBS	24 LBS	28 LBS
PC/ Master Pack	6		

Project Name: \_\_\_\_\_

Date: \_\_\_\_\_ Note: \_\_\_\_\_

## LED DOUBLE RING FLUSH MOUNT CEILING LIGHT (AC120-277V)

### ORDERING CODE DEFINITION

#### HY-DR12-16WCCT(MS) / HY-DR12-16WCCT(MS+EM)

Company Code	Product	Size	Power	CCT	Suffix
HY	DR: Double Ring Flush Mount Ceiling Light	12" 14" 16"	12": 16W 14": 22W 16": 26W	5 CCT Selectable: 2700K/3000K/3500K/4000K/5000K	<b>MS+EM:</b> Bi-level Daylight Harvesting Microwave Sensor & Emergency Backup.

### PRODUCT DIMENSIONS

Front View

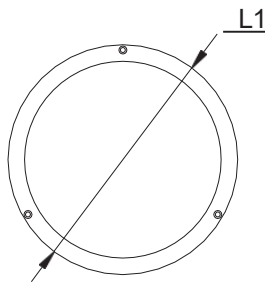

Side View

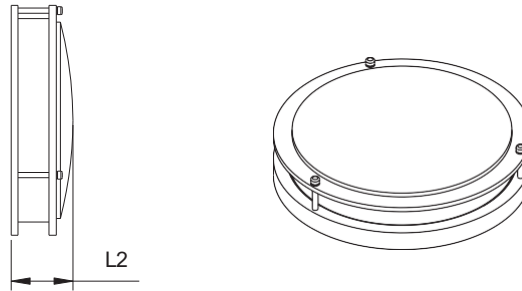

Model NO	HY-DR12-16WCCT(MS+MS)	HY-DR14-22WCCT(MS+EM)	HY-DR16-26WCCT(MS+EM)
Size			
L1	Φ305mm/Φ12"	Φ355mm/Φ14"	Φ405mm/Φ16"
L2	104mm/4.09"	114mm/4.49"	124mm/4.89"

### INSTALLATION INSTRUCTION

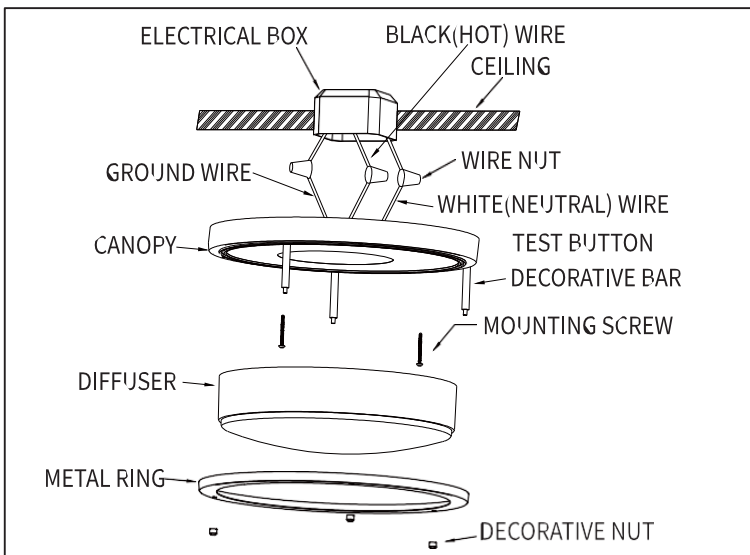

**Tools Needed:**

Screwdriver, pliers, wire nuts, and electrical tape.

**Safety:**

- Wear rubber-soled shoes to prevent electric shock.
- Handle the fixture carefully to avoid cuts.
- Use a sturdy ladder if needed.

**1. Mounting the Fixture:**

Screw the long mounting screws into the electrical box about two full turns. *(Included.)*

**2. Electrical Connection:**

Turn off the power. Connect green/bare wire to ground, white to white, and black to black. Secure with wire nuts and tape.

**3. Attach Canopy:**

Place the canopy over the screws, align with the keyhole slots, rotate, and tighten until snug.

**4. Install Diffuser:**

Align the diffuser, place the metal ring, and secure with three decorative nuts.

Project Name: \_\_\_\_\_

Date: \_\_\_\_\_ Note: \_\_\_\_\_

## LED DOUBLE RING FLUSH MOUNT CEILING LIGHT (AC120-277V)

### SENSOR INSTALLATION

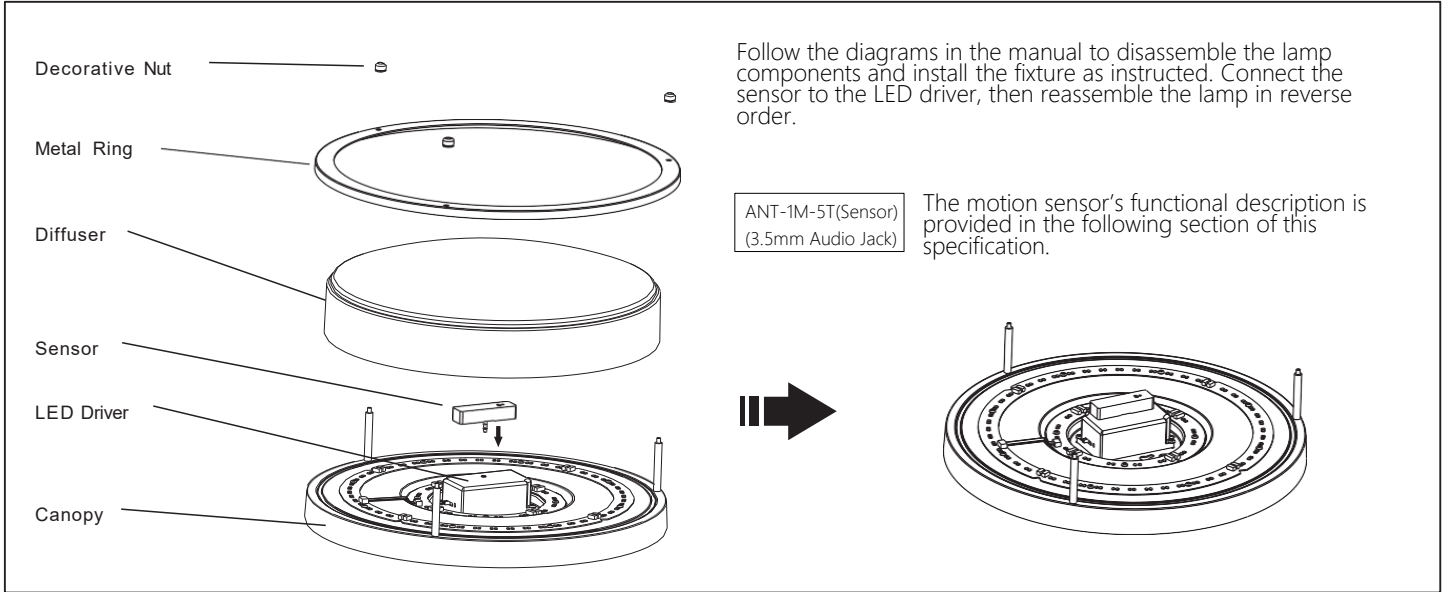

### OPERATING GUIDE

#### CCT Adjustable

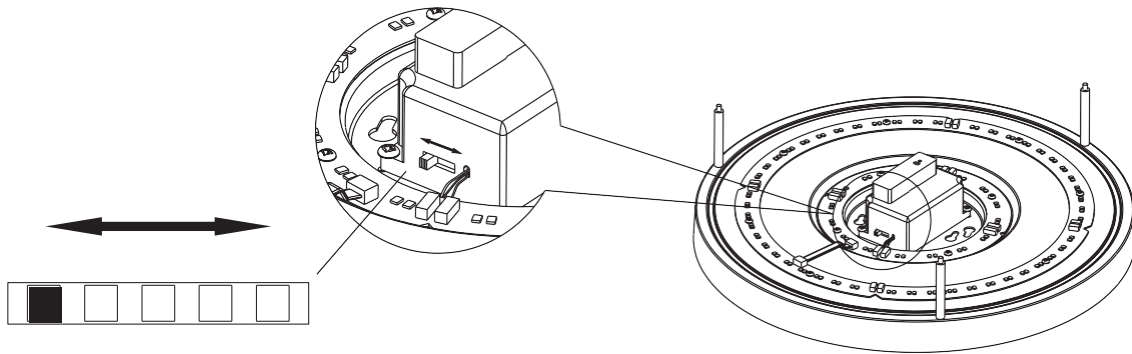

#### Wiring Guide

**CAUTION:** turn off electrical power at fuse or circuit breaker box before wiring fixture to power supply

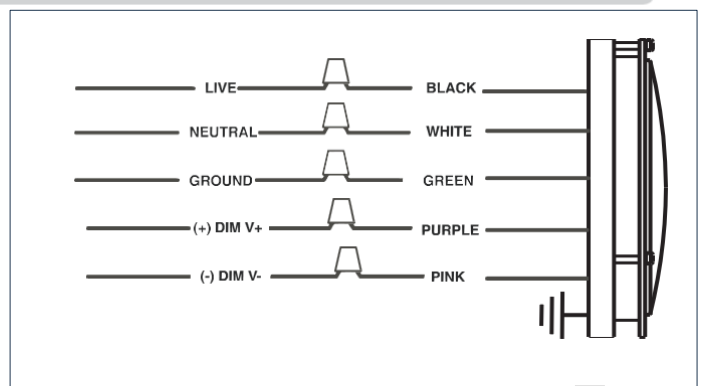
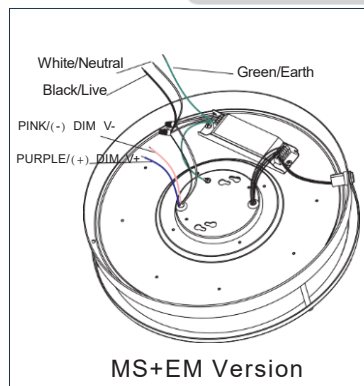
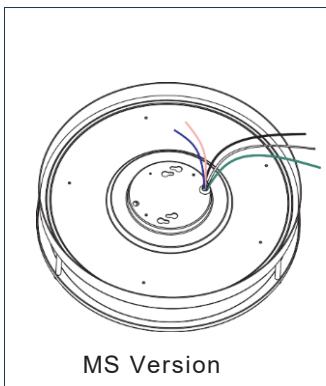

Project Name: \_\_\_\_\_

Date: \_\_\_\_\_ Note: \_\_\_\_\_

## LED DOUBLE RING FLUSH MOUNT CEILING LIGHT (AC120-277V)

### PHOTOMETRIC REPORT

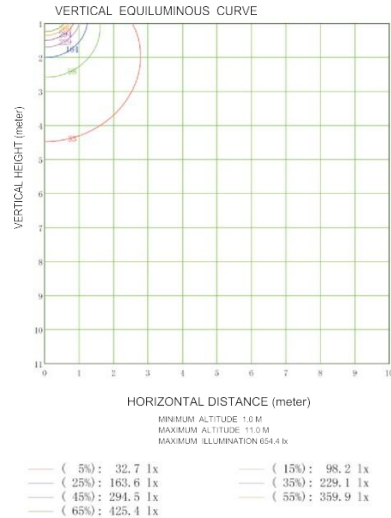
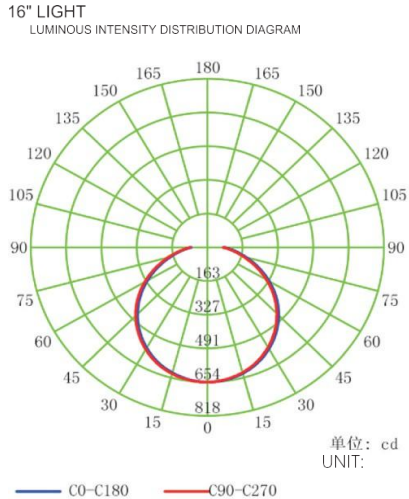

### BI - LEVEL DAYLIGHT HARVESTING MICROWAVE SENSOR



ANT-1M-5T ( sensor )  
(3.5mm Audio Jack)



RC-100

**Note:**

1. Warm-up Time: 15 seconds.

When the sensor is powered on for the first time, the light will remain on for 15 seconds before dimming and entering normal operation.

2. Factory Default Settings:

Hold Time: 1 min  
Standby Brightness: 30%  
Standby Time: 30 min  
Sensitivity: 100%  
Daylight Sensor: Disabled ( ☼ )



With sufficient natural light, the light does not switch on when presence detected.



With insufficient natural light, the sensor switches on the light automatically when person enters room.



People left, light still dims to 0/10%/30%/50% (options) standby level after the hold time.



Light switches off automatically after after stand-by time elapsed.

### Emergency LED Driver

**Circuit Diagram:**

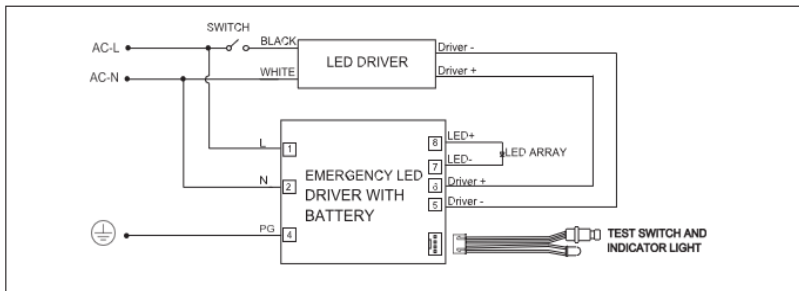

- \* Output Power 2W,3W,4W
- \* Emergency Time: 1.5H
- \* Universal Input Voltage 100-277 Vac, 50/60 HZ
- \* AC Input Current 100mA Max
- \* AC Input Power Rating 5.0W Max
- \* Output Current & Voltage 300-400mA 10-60Vdc

- \* Full Warranty: 5-year
- \* Test Switch Indicator Light Illuminated Test Switch, Indicator Light
- \* Battery Li-ion battery- 3.7V/2500mAh
- \* Battery Charging Current 250mA Max
- \* Charging Time ≥24 hours
- \* Temperature Rating (Ambient) Li-ion 0°C to 50°C(32°F-120°F)