





# EMERGENCY LED DRIVER EM-0825-010/105-P2



### Product features

- 1050mA output Current max
- SELV for output voltage < 60 V DC
- Programmable constant current
- Open Circuit Protection
- Short Circuit Protection
- No PCB
- Sound Rated A
- UL / cUL R/C, Class 2
- FCC Part 15 Class B
- 5 Years Limited Warranty

ELECTRICAL DATA		Markings
Input voltage	120-277VAC 50/60Hz	   
Input current	100mA MAX.	
Power fact	0.6	
Recharge power	8W MAX.	
Standby power	<0.5W	
Red Lead	3A,90V	
White/black Lead	100W MAX.	
Output current	100~1050mA	
Output voltage	11~56V	
Output power	25W MAX.	
Output short protection	YES	
Output open protection	YES	
Ambient temperature	0°C ~50°C	
Ambient temperature2	0°C ~50°C LiFePO4	
Tc MAX	70°C	
Time to light	0.3S from detection of emergency event	
Recharge time required	24- 48Hours (Refer to battery chart)	
Battery type	LiFePO4 9.6VDC	
Battery capacity available	0.9Ah~6Ah	

# EMERGENCY LED DRIVER EM-0825-010/105-P2

## WIRING DIAGRAMS

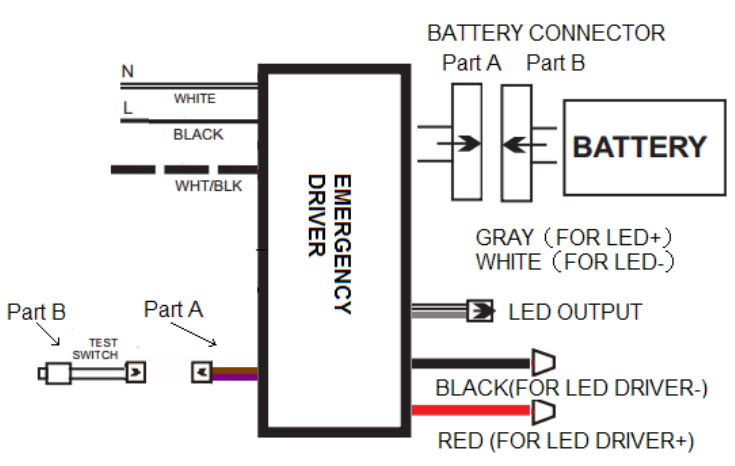
	Wire	Length (inches)
	WHITE	13.0
	BLACK	13.0
	WHT/BLK	15.0
	Battery connector(Part A)	1.20
	Battery connector(Part B)	12.0
	Test switch(Part A)	1
	Test switch(Part B)	24.0
	Black(for LED Driver-)	21.0
	Red(for LED Driver+)	21.0
LED OUTPUT	21.0	

## MECHANICAL DATA

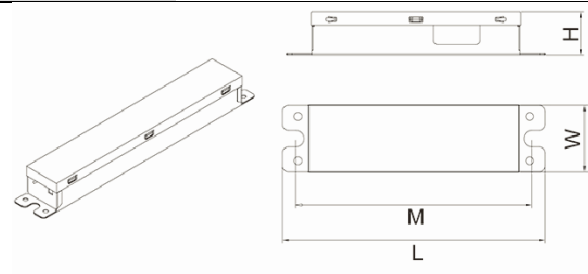
	Dimension	Length (inches)
	H	1.00
	W	1.72
	L	5.89
	M	5.30

## WIRING DIAGRAM (TYP)

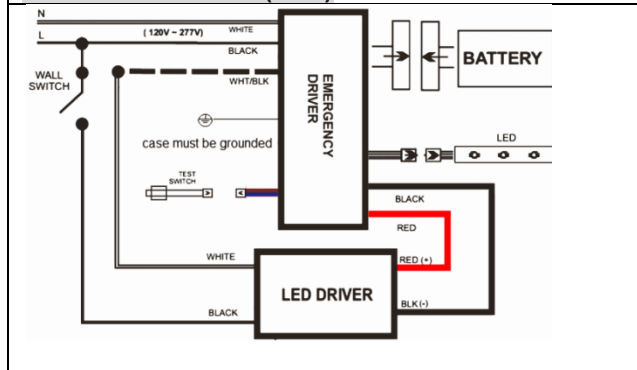

## WIRING DIAGRAM (EMERGENCY ONLY)

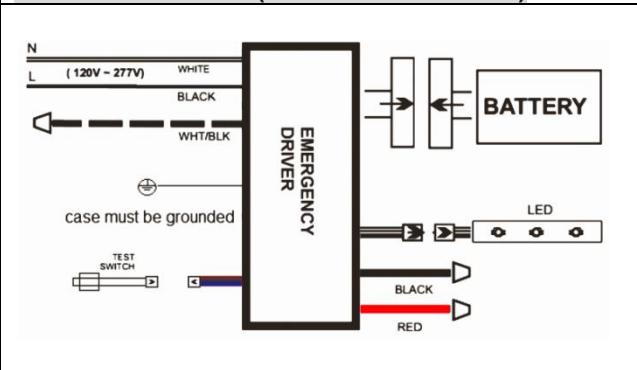

# EMERGENCY LED DRIVER EM-0825-010/105-P2

## BATTERY CHART

Batter Order Code	Dimension (LxWxH)	Battery Type	Capacity	Wattage	Battery Voltage	Re-Charging Time
5W-L	8.1" x 1.10" x 0.84"	LiFePO4	1000mAH	5W	9.6V	24 Hrs
8W-L	8.1" x 1.10" x 0.84"		1500mAH	8W	9.6V	24 Hrs
16W-L	9.37" x 1.22" x 1.20"		3000mAH	16W	9.6V	32 Hrs
25W-L	9.37" x 2.24" x 1.20"		6000mAH	25W	9.6V	48 Hrs
5W-Q	3.62" x 2.70" x 0.98"		1000mAH	5W	9.6V	24 Hrs
8W-Q	3.62" x 2.70" x 0.98"		1500mAH	8W	9.6V	24 Hrs
16W-Q	4.61" x 2.83" x 1.20"		3000mAH	16W	9.6V	32 Hrs
25W-Q	4.61" x 2.83" x 2.38"		6000mAH	25W	9.6V	48 Hrs

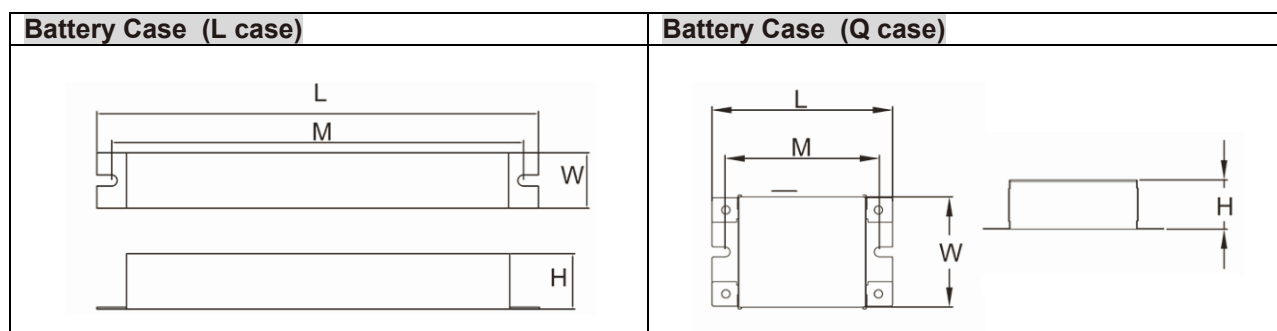

**Wattage: Max load for 90 minutes**

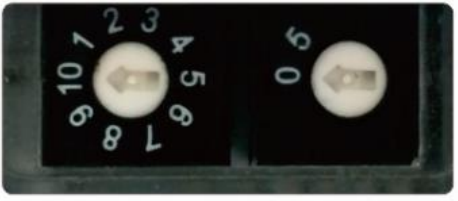
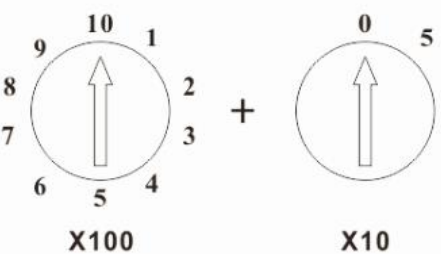
Program Switch	Features
 	<p><b>Programmable Constant Current</b></p> <ul style="list-style-type: none"> <li>• Pre-set by factory</li> <li>• Adjust it by yourself</li> </ul> <p><b>Adjustable Output Current</b></p> <ul style="list-style-type: none"> <li>• 10 ranges</li> <li>• 50mA per scale</li> </ul>



## EMERGENCY LED DRIVER EM-0825-010/105-P2

### IMPORTANT SAFE PRACTICES

PLEASE READ CAREFULLY AND FOLLOW ALL INSTRUCTIONS FOR YOUR OWN SAFETY

IMPORTANT: An un-switched AC power source of 100V AC to 277V AC is required.

- This device is designed for use in fixtures listed for dry and damp locations.
- CAUTION: Make sure all electrical connections conform to the National Electrical Code and all applicable local regulations.

CAUTION: Do not let power supply cords touch hot surfaces.

CAUTION: Do not mount near gas or electric heaters.

- CAUTION: Battery is rechargeable LiFePO4 type and must be recycled or disposed of properly.
- Do not use this emergency driver with accessory equipment other than recommended by manufacturer. Failure to follow this may cause an unsafe condition. Servicing should only be performed by qualified service personnel.
- Do not use this emergency driver for other than intended use. Equipment should be mounted in locations and at heights where it will not readily be subjected to tampering by unauthorized personnel.