

# LEDone

Projects:

Comments:

## 90W LED Surface Mount Canopy Fixture

### SPECIFICATIONS:

<b>WATTAGE:</b>	90W
<b>DLC WATTAGE:</b>	87.07W
<b>DLC &amp; MODEL #:</b>	CPSM90HU50KFP
<b>CERTIFICATIONS:</b>	ETL, cETL, FCC, CE, RoHS, DLC
<b>LED CHIP:</b>	Hongli
<b>LUMENS:</b>	8024.48LM
<b>LUMENS EFFICACY:</b>	92.17 lm/w
<b>THD:</b>	22%
<b>VOLTAGE:</b>	AC120-277V
<b>POWER FACTOR:</b>	0.915
<b>POWER CONSUMPTION:</b>	90W
<b>KELVIN (CCT):</b>	5030 k
<b>CRI:</b>	83.7
<b>IP RATING:</b>	IP65
<b>LIFE SPAN (HOURS):</b>	50,000 Hours
<b>DIMMING COMPATIBLE:</b>	0-10V Dimming optional
<b>LENGTH OF WARRANTY (YEARS):</b>	5 Years Standard
<b>FIXTURE MATERIAL:</b>	Die Cast Aluminum and Bronze Finish
<b>DIMENSIONS (L X W X H)</b>	315x315x229mm (12.4x12.4x9 in)
<b>MOUNTING OPTIONS:</b>	Recessed Outlet Box or Ceiling Surface
<b>WORKING ENVIRONMENT:</b>	-34°C to 54°C (-30°F to 130°F)
<b>SUGGESTED REPLACEMENT FOR:</b>	400W
<b>PERCENTAGE OF WATTAGE SAVED:</b>	75%

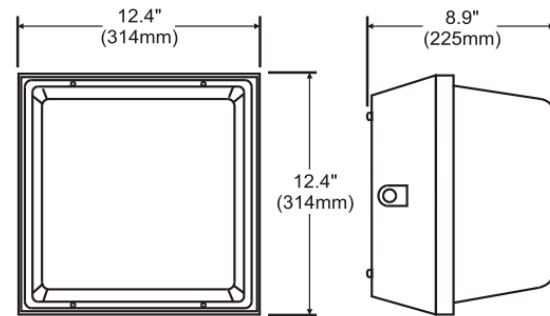

\*\*\* Note: Specifications are based on DLC's website. Actual product may have slight variations in tolerance range.

### Features:

One-piece die-cast aluminum housing. One-piece silicone perimeter lens gasket and closed-cell neoprene housing gasket help to seal out moisture and contaminants. High quality shock proof polycarbonate lens with UV inhibitors. Integral secondary heat sink to optimize thermal transfer and maximize performance and life of LED. Driver is mounted in direct contact with the casting for low operating temperature and long life. Polyester powder-coated finish, rust and corrosion proof.

### Applications:

Utility ceiling-mount fixture for general lighting applications in parking garages, designed for easy installation and maintenance. Can also be used to light entrances, hallways, walkways, atm machines, and drive-thrus.

