

LEDone

Projects:

Comments:

90W LED Surface Mount Canopy Fixture

SPECIFICATIONS:

WATTAGE:	90W
MODEL #:	CPSM90HU50KFP
LISTED:	ETL, cETL, FCC, CE, RoHS, DLC
LED CHIP:	Hongli
LUMENS:	8024.48LM
LUMENS EFFICACY:	92.17 lm/w
THD:	22%
VOLTAGE:	AC120-277V
POWER FACTOR:	0.915
POWER CONSUMPTION:	90W
KELVIN (CCT):	5030 k
CRI:	83.7
IP RATING:	IP65
LIFE SPAN (HOURS):	50,000 Hours
DIMMING COMPATIBLE:	0-10V Dimming optional
LENGTH OF WARRANTY (YEARS):	5 Years Standard
FIXTURE MATERIAL:	Die Cast Aluminum and Bronze Finish
DIMENSIONS (L X W X H)	315x315x229mm (12.4x12.4x9 in)
MOUNTING OPTIONS:	Recessed Outlet Box or Ceiling Surface
WORKING ENVIRONMENT:	-34°C to 54°C (-30°F to 130°F)
SUGGESTED REPLACEMENT FOR:	400W
PERCENTAGE OF WATTAGE SAVED:	75%

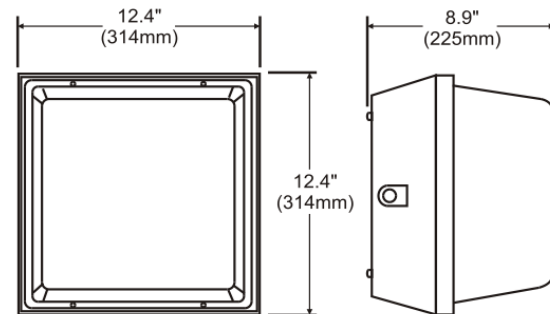

Features:

One-piece die-cast aluminum housing. One-piece silicone perimeter lens gasket and closed-cell neoprene housing gasket help to seal out moisture and contaminants. High quality shock proof polycarbonate lens with UV inhibitors. Integral secondary heat sink to optimize thermal transfer and maximize performance and life of LED. Driver is mounted in direct contact with the casting for low operating temperature and long life. Polyester powder-coated finish, rust and corrosion proof.

Applications:

Utility ceiling-mount fixture for general lighting applications in parking garages, designed for easy installation and maintenance. Can also be used to light entrances, hallways, walkways, atm machines, and drive-thrus.

